

ORCOMM[®]

INSTALLATION MANUAL

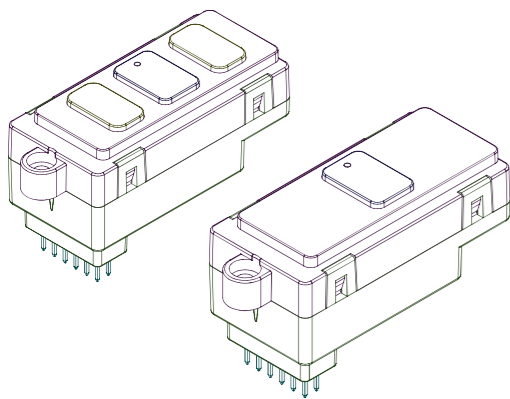

DIGILUX MODULES

Contents:

- 1 x Digilux module (Switch/Dimmer)
- 1 x Fixing screws

Compliance And Standards:

The Digilux products use a IEEE 802.15.4 Zigbee mesh network to build and secure communications between all end points to allow wireless control.

The product complies with all the basic requirements and other relevant provisions of the 1999/5/EC directive using a TUV CE standard and process. For full details of this please contact support@orcomm.co.uk.

Operation is subject to the following two conditions: (1) This device may not cause harmful interference, and (2) this device must accept and interference received, including that may cause undesired operation.

Installation of the product must be carried out by a qualified person conforming to all standards set out by law of intalled country.



Before you start:

Please ensure that all power is removed from the circuit before installing the Digilux modules.

The Digilux modules are only compatible with the following control backboxes:

- DILX-1G-CB
- DILX-2G-CB
- DILX-3G-CB
- DILX-4G-CB

Please ensure that the control backbox is installed and connected as per the product installation manuals.

Ensure that you are using the correct module for the correct lighting circuit.

Do not continually install and remove modules. This may lead to non-repairable damage not covered by warranty.

Module Types:

Dimmer Module

The dimmer module can control compatible dimmable light sources using phase leading/trailing edge dimming controls.

Maximum load per dimmer module is 150W.

Do not mix different light source types on the same module.

Do not mix dimmable and non-dimmable light sources on the same module.

Do not connect to circuits that require switch live. e.g. Boost/MVHR or demister pads.

Switch Module

The switch module is for switching loads with a maximum load of 200W.

Do not mix different light source types on the same module.

Do not mix dimmable and non-dimmable light sources.

Module Installation:

Once the control backbox has been installed and connected the unit is ready to be installed with the switch or dimmer modules (Sold separately). A combination of modules can be used on the same control backbox.

Please make sure that NO power is being fed to the lighting circuit until all modules have been installed.

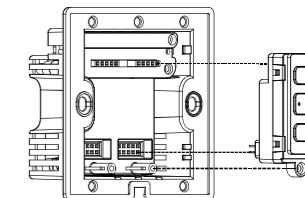

During installation of the modules care should be taken to ensure that the connecting pins are lined up and straight before fully inserting. Please DO NOT continually remove and install the modules.

Once the module is installed secure with the screw provided.

V1.1

Module assignment:

You are able to mix different modules in different locations within the control backbox. Please ensure that you match the channel with the correct terminal on the rear of the device.

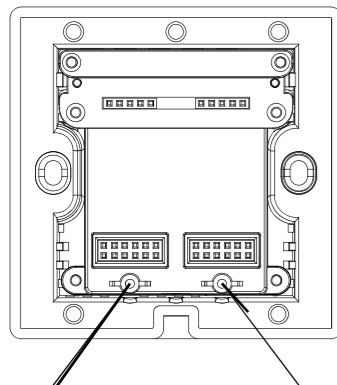

Module Channel 1 Back Terminal - L1
Module Channel 2 Back Terminal - L2

Maximun load: Switch Module = 150W / Dimmer Module = 150W

Faceplate:

Once all modules have been installed the faceplate can be installed. Please ensure that the locating tabs are aligned before seating into position.

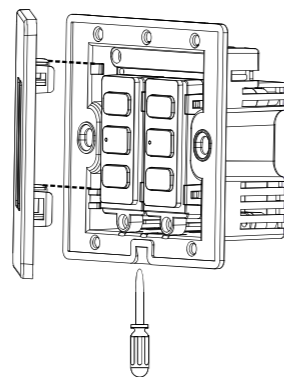

Removing the faceplate can be done using a small 4-6mm flat blade screwdriver.

Where possible secure the backbox against the wall while levering the faceplate off to prevent box being pulled away from the wall.

Warranty:

Orcomm provides warranty for this product against defects due to workmanship or materials but does not cover damage or breakdown due to; normal wear, abuse, improper maintenance, disassembly of parts, scratches to the finish (Normal Wear) attempted repair, natural disaster and force majeure.

The warranty excludes, among other item; installation, providing access to products and special incidental and consequential damages. (Loss of revenue / profits, damages to property or miscellaneous cost not previously mentioned).

Subject to the conditions as set forth by the "Conditions of warranty" and set forth hereunder, the purchaser receives the RTB warranty for the applicable period of 2 years.

Conditions of warranty:

This warranty covers products within their intended or normal use as defined by the following:

Operation conditions are in accordance with the information on the product, datasheet and its packaging.
The warranty periods starts from the date of invoice.
The products have been properly installed and operated in accordance with the manufacturer's instructions.
Adequate records of operating history are retained and available to the manufacture for review.
We will have access to the defective product, if the product or other components become suspect, then we have the right to evaluate the lighting system with the assistance of a third party.

Ambient temperatures never exceed the operation temperature range of -10°C to +40°C
Relative humidity in the installation location never exceeds the range of 20% - 85% RH
Product are not subjected to more than 50,000 switched cycles.
The electrical installation in which the product operates is not subjected to voltage fluctuaton in a range exceeding 230 VAC + 10%.
Labour cost for installation or de-installation of the products are not covered under this warranty.

Orcomm cannot be held liable for electrical supply conditions, including spikes, over / under voltage and ripple current control systems that are beyond the specific limits of our products and those defined by relevant installation and environmental standards.

Warranty claims:

Warranty claims have to be reported to Orcomm within 20 days of discovery, specifying the following information. Part code, batch number, installation date, number and percentage of failures, application, hours used and estimated number of cycles.

Maintenance of devices:

Keep the surface clean with a dry cloth or appropriate cleaner containing no acids, benzene, thinners, or solvents. The use of the above may cause damage to the casing or the surface finish / colour.

Failure to follow theses directions could invalidate all warranties.

Returns policy:

Return shipping even if the item is defective should be paid for by the buyer.

We do not provide any refunds as per our terms of sales.

Full details of returns are covered in our standard terms of sales agreed to upon account opening.

Operation and further information:

Full operation and user manuals are available from downloads.orcomm.co.uk

Support and aftercare:

In the event of support or aftercare please email: support@orcomm.co.uk

Dimming Performance:

Orcomm cannot be held liable for dimming performance due to 3rd party lamps, environmental factors, power supply and site configurations.

It is highly advised that performance testing is undertaken with chosen light sources before permanent installation takes place.