

INSTALLATION MANUAL ORC – 7TF (v2)

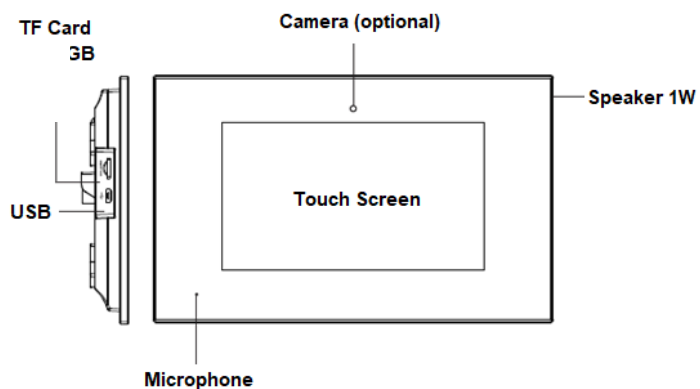

Installation:

1. Mounting the Internal Touch Screen

Cut hole in wall for a standard double gang electrical back box (35mm deep)
Screw bracket to back box using 3.5mm screws
Push monitor down onto bracket (click to confirm lock)

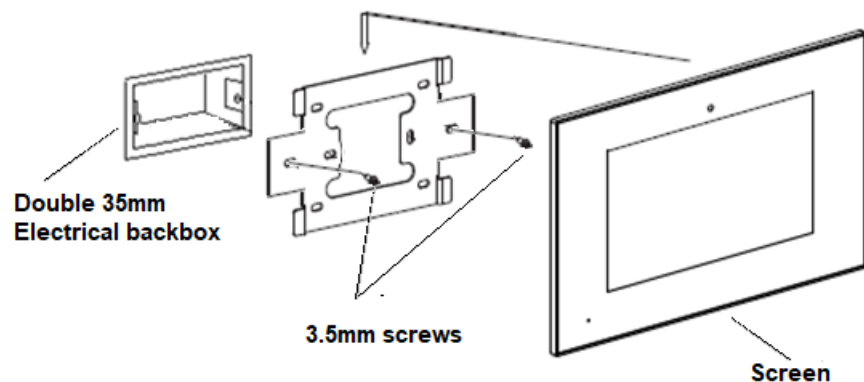

2. Connecting cables

Connect POE Ethernet cable into Network port rear of monitor

12V DC 1A
optional power input

ORC-NET
optional use for Smart Home communication

Inputs
Door bell (A1)
Smoke (A2)
Water Leak (A3-A8)

12V DC 200mA (max)

Door Bell (Com / No)

Smoke Alarm Relay

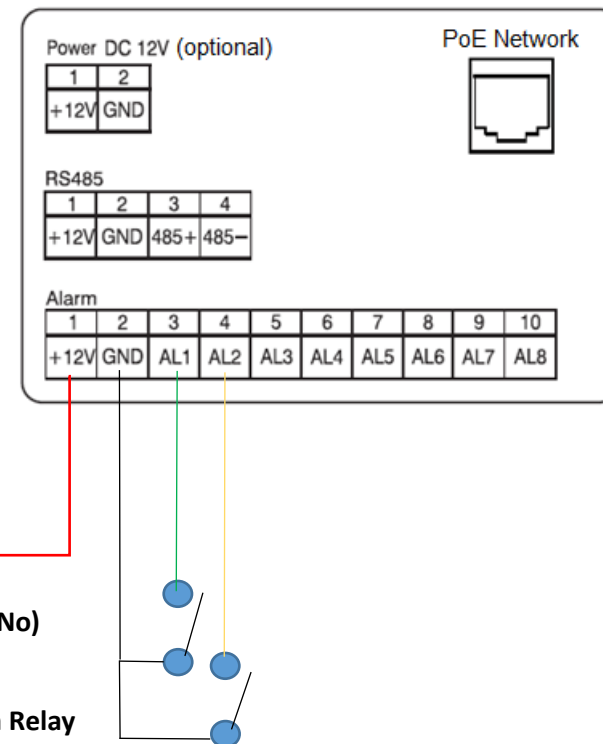

Warranty:

Orcomm provides warranty for its Door Entry products against defects due to workmanship or materials but does not cover the damage due to; normal wear, abuse, improper maintenance, disassembly of parts, scratches to the finish (considering normal wear), attempted repair, natural disaster and force majeure.

This warranty excludes, among other items; installation, providing access to products (scaffolding, lifts, etc) and special incidental and consequential damages. (Loss of revenue / profits, damages to property or other miscellaneous cost not previously mentioned.

Subject to conditions as set forth by the “conditions of warranty” and as set forth hereunder, the purchaser receives the warranty for the applicable period of 2 years.

Conditions of warranty:

This warranty covers products within their intended or normal use as defined by the following:

Operation conditions are in accordance with the information on the product and its packaging.

The warranty periods starts from the date of invoice.

The products have been properly installed and operated in accordance with the manufacturer’s instructions.

Adequate records of operating history are retained and available to the manufacturer for review.

We will have access to the defective product. If the product or other components become suspect, then we have the right to evaluate the lighting system with the assistance of a third party.

Ambient temperatures never exceed the operating temperature range -10°C to +40°C
Relative humidity in the installation never exceeds the IP rating of the product, if any is provided.

Products are not subject to more than 50,000 switch cycles.

The electrical installation in which the product operates is not subjected to voltage fluctuations in a range exceeding 230V + - 10%

Labour cost for (de) – Installation of the products are not covered under the warranty.

Warranty Claims:

Warranty claims have to be reported to us within 20 days of discovery, specifying the following the information.

Details of the failed product. (Part code and batch number) Installation and invoice dates.

Detailed description of the problem, with number and percentage of failures. Application, hours used and estimated number of switch cycles.

Maintenance of devices

Keep the surface clean with a dry cloth or appropriate metal cleaner.

Do not use benzene, thinner or organic solvents such as gasoline to clean, these solvents may cause damage to the machine casing or the surface of machine and change colours.

We cannot be held liable for electrical supply conditions, including spike, over voltage / under voltage and ripple current control systems that are beyond the specific limits of our products and those defined by relevant standards.

Return Policy:

Buyer must pay return shipping charges under all circumstances, even if the item is defective.

Seller will promptly ship the replacement at no charge.

We do not provide any refunds. In extremely rare circumstances, if we do decide to provide a refund, there will be 20% restocking fees. Items sold as is will not be covered by this policy, in which case it will be clearly stated in the item description.

Shipping & handling charges are non-refundable.

Short-shipments, DOA (Dead on Arrival) and deviation products must be reported within 5 days from the delivered date.

Returned items must not have any signs of abuse or intentional damage.

We carefully inspect returned items upon receipt before issuing refunds, credits or exchanges. Lights which are used for a purpose other than which they were designed for, or have been altered in any way that would be detrimental to the performance or life of the product or misapplication, misuse, negligence or accident will not be covered.

Please keep all packaging, documentation, packing list, etc. that came with your order. These will be used to verify claims if there are any problems with your order

This product complies with all basic requirements and other relevant provisions of the 1999/5/EC directive. For the full wording of the Declaration of Conformity can be found on our website at www.orcomm.co.uk

This device complies with part 15 of the FCC Rules. Operation is subject to the following two conditions: (1) This device may not cause harmful interference, and (2) this device must accept any interference received, including interference that may cause undesired operation.

The company is the holder of the ISO 9001:2009 certificate. All development, production and distribution processes of the company are managed by this standard and guarantee a high quality, technical level and professional aspect of all our products.

